



TRILLA

CATÁLOGO GENERAL | *GENERAL CATALOGUE*





INYECCIÓN DE PLÁSTICOS DESDE 1955

Con más de 70 años de experiencia, Trilla diseña y fabrica soluciones plásticas duraderas e innovadoras para los sectores industrial, agrícola y logístico. Desde sus 40.000 m² de instalaciones tecnológicamente avanzadas en Madrid, transforma más de 7.000 toneladas de plástico al año.

Certificada bajo ISO 9001 e ISO 14001, Trilla une calidad, eficiencia y sostenibilidad, utilizando material reciclado, procesos sin residuos y energía solar. Todos sus productos son 100% reciclables y optimizados para el transporte y la reutilización.

Fiabilidad, innovación, sostenibilidad y servicio definen el liderazgo de Trilla.

PLASTIC INJECTION SINCE 1955

With over 70 years of experience, Trilla designs and manufactures durable and innovative plastic solutions for industrial, agricultural, and logistics sectors. From its 40,000 m² high-tech facility near Madrid, it transforms more than 7,000 tons of plastic annually.

Certified under ISO 9001 and 14001, Trilla combines quality, efficiency, and sustainability, using recycled materials, zero-waste processes, and solar-powered machinery. All products are 100% recyclable and designed for optimal transport and reuse.

Reliability, innovation, sustainability, and service define Trilla's leadership.



**MÁS DE
70 AÑOS
CREANDO
SOLUCIONES**

*OVER
70 YEARS
SHAPING
SMART
SOLUTIONS*

CAJAS APILABLES

Stackable crates 4

CAJAS ENCAJABLES

Nestable crates..... 22

CAJAS APILABLES Y ENCAJABLES

Stackable and nestable crates.....25

BANDEJAS DE EXPOSICIÓN

Tray display and preservation33

CUBOS Y BARREÑOS

Bins and buckets35

CONTENEDORES INDUSTRIALES

Industrail containers.....39

GRANDES CONTENEDORES Y PALETS

Large containers and pallets42

TARIMAS Y SUELOS

Floorboards and flooring48

ÍNDICE POR REFERENCIAS

Reference index50

ÍNDICE POR MEDIDAS

Measurement index.....53

ECONOMÍA CIRCULAR APLICADA EN ORIGEN

Circular economy applied at home56

DATOS GENERALES

General information58

CAJAS APILABLES *STACKABLE CRATES*

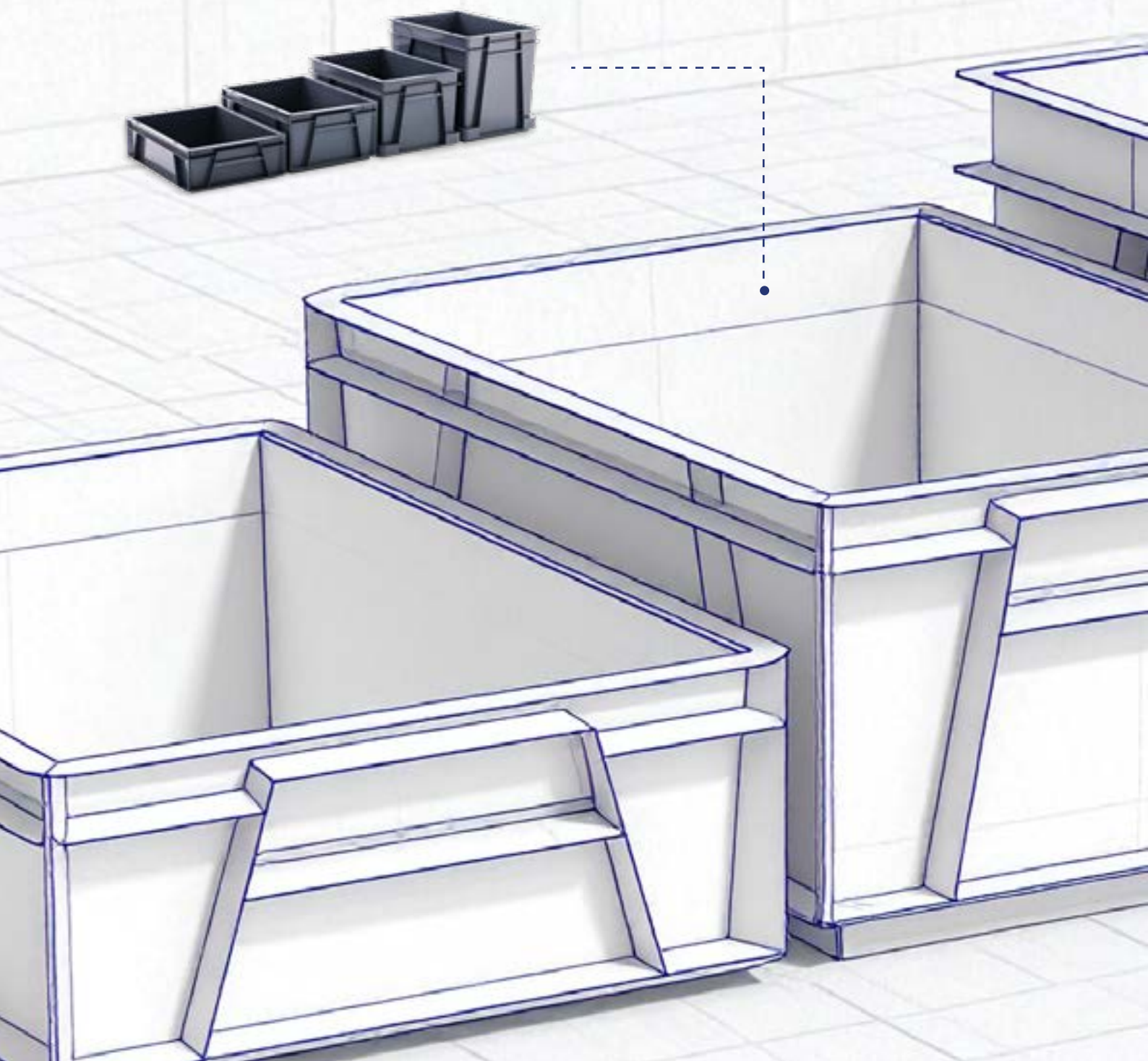

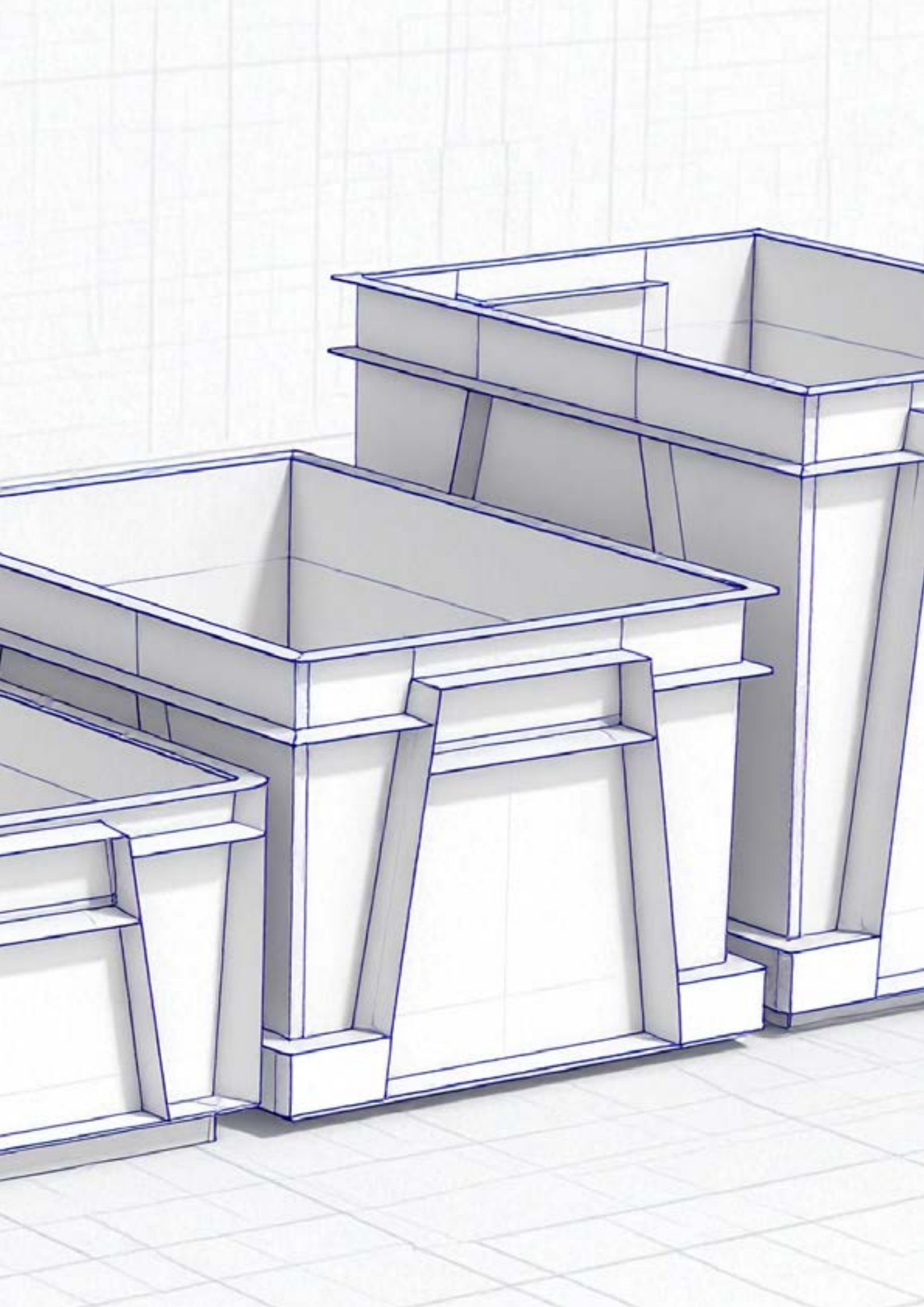



70300

PEAD



400 x 300 x 120 mm.

370 x 270 x 116 mm.

0,750 kg

 170 u. / palet
100 x 120 x 220 cm.

10 l.

70410 | 70411

PEAD



400 x 300 x 175 mm.

368 x 265 x 167 mm.

0,900 kg

 140 u. / palet
100 x 120 x 220 cm.

15 l.

70410

70411

70400 | 70401

PEAD



400 x 300 x 230 mm.

370 x 267 x 226 mm.

1,020 kg

 90 u. / palet
100 x 120 x 220 cm.

20 l.

70400

70401

70430 | 70431

PEAD



400 x 300 x 325 mm.

365 x 264 x 317 mm.

1,480 kg

 70 u. / palet
100 x 120 x 220 cm.

30 l.

70430

70431

72651

PP



400 x 300 x 16,5 mm.

0,280 kg

 208 u. / palet
100 x 120 x 220 cm.

80 u. / caja

 16 cajas / palet
100 x 120 x 220 cm.



CAJAS APILABLES / STACKABLE CRATES

01

NE64 Norma Europa 600 x 400 / NE64 European Standards 600 x 400

70360

PEAD



600 x 400 x 120 mm.

570 x 370 x 116 mm.

1,430 kg

85 u. / palet
100 x 120 x 220 cm.

23 l.



70370

PEAD



600 x 400 x 170 mm.

570 x 370 x 150 mm.

1,800 kg

70 u. / palet
100 x 120 x 220 cm.

30 l.

70371

PEAD



600 x 400 x 170 mm.

570 x 370 x 150 mm.

1,680 kg

70 u. / palet
100 x 120 x 220 cm.

30 l.

70380 | 70382

PEAD



600 x 400 x 230 mm.

570 x 370 x 226 mm.

1,880 kg

45 u. / palet
100 x 120 x 220 cm.

45 l.

70380

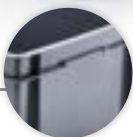

70382



70381 | 70383

PEAD



600 x 400 x 230 mm.

570 x 370 x 226 mm.

1,540 kg

45 u. / palet
100 x 120 x 220 cm.

45 l.

70381



70383



70660

PEAD

 600 x 400 x 325 mm.

 570 x 370 x 305 mm.

 2,900 kg

 35 u. / palet
100 x 120 x 220 cm

 60 l.

70661

PEAD

 600 x 400 x 325 mm.

 570 x 370 x 305 mm.

 2,491 kg

 35 u. / palet
100 x 120 x 220 cm

 60 l.

70920

PEAD

 600 x 400 x 425 mm

 570 x 370 x 405 mm

 3,650 kg

 25 u. / palet
100 x 120 x 220 cm

 90 l.

70921

PEAD

 600 x 400 x 425 mm.

 570 x 370 x 405 mm.

 3,100 kg

 25 u. / palet
100 x 120 x 220 cm

 90 l.

71110

PP

 600 x 400 mm.

 0,630 kg

 200 u. / palet
100 x 120 x 220 cm

72662

PP

 600 x 400 mm.

 0,690 kg

 208 u. / palet
100 x 120 x 220 cm



CAJAS APILABLES / STACKABLE CRATES

01

CARROS Portacajas / Dollys



70720

PP



 600 x 400 x 175 mm.

 1,760 kg

 48 u. / palet
80 x 120 x 220 cm.

 100 kg
carga estática / static load

Ø 75 mm.

70710

PP



 600 x 400 x 175 mm.

 3,500 kg

 48 u. / palet
80 x 120 x 220 cm.

 150 kg
carga estática / static load

Ø 100 mm.

70750

ABS



 600 x 400 x 140 mm.

 2,600 kg

 48 u. / palet
80 x 120 x 220 cm.

 200 kg
carga estática / static load

Ø 80 mm.

70751

PP



 600 x 400 x 170 mm.

 3,000kg

 48 u. / palet
80 x 120 x 220 cm.

 250 kg
carga estática / static load

Ø 100 mm.



SISTEMAS DE ALMACENAMIENTO AUTOMATIZADO

AUTOMATED STORAGE SYSTEMS

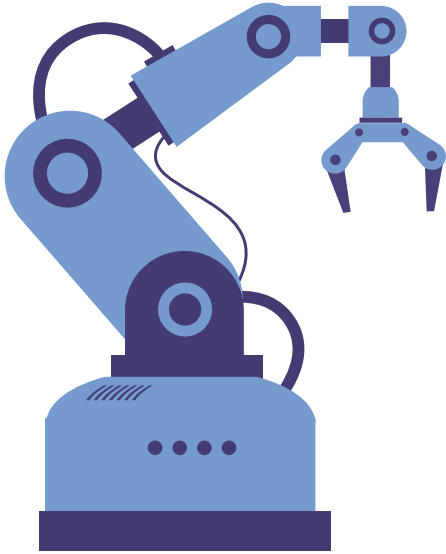

70560

PP

 625 x 425 x 123 mm

 607 x 407 x 113 mm

 1,990 kg

 72 u. / palet
80 x 120 x 220 cm

 28 l.

70562

PP

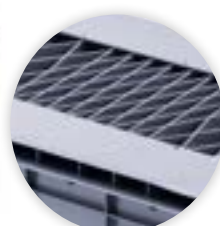
 625 x 425 x 145 mm

 605 x 405 x 130 mm

 2,150 kg

 72 u. / palet
80 x 120 x 220 cm

 28 l.



70119

PEAD



 400 x 400 x 80 mm.

 383 x 383 x 71 mm.

 0,840 kg

 150 u. / palet
80 x 120 x 220 cm.

 12 l.

70120

PEAD



 600 x 400 x 64 mm.

 568 x 368 x 54 mm.

 0,840 kg

 164 u. / palet
80 x 120 x 220 cm.

 12 l.

73270

PEAD



 600 x 400 x 72 mm.

 563 x 363 x 70 mm.

 0,995 kg

 180 u. / palet
100 x 120 x 220 cm.

 14 l.

73271

PEAD

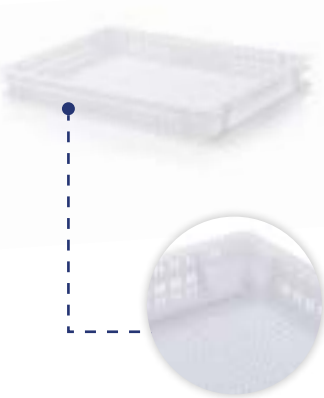

 600 x 400 x 72 mm.

 563 x 363 x 70 mm.

 0,890 kg

 180 u. / palet
100 x 120 x 220 cm.

 14 l.

70122

PEAD



 600 x 400 x 100 mm.

 568 x 368 x 90 mm.

 1,312 kg

 148 u. / palet
80 x 120 x 220 cm.

 19 l.

70130

PP



 646 x 445 x 81 mm.

 606 x 405 x 75 mm.

 1,308 kg

 160 u. / palet
100 x 120 x 220 cm.

 18 l.

73050

PEAD

 600 x 400 x 120 mm.

 564 x 360 x 109 mm.

 1,260 kg

 100 u. / palet
100 x 120 x 220 cm

 26 l.

73060

PEAD

 600 x 400 x 170 mm.

 568 x 360 x 158 mm.

 1,597 kg

 65 u. / palet
100 x 120 x 220 cm.

 32 l.

73160

PEAD

 600 x 400 x 230 mm.

 564 x 360 x 220 mm.

 1,850 kg

 40 u. / palet
100 x 120 x 220 cm.

 44 l.



71220

PEAD

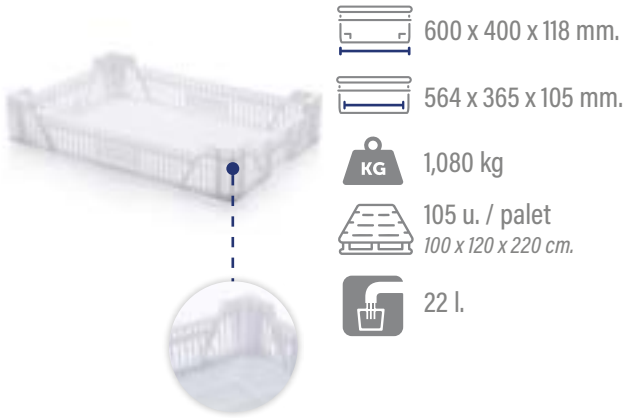

71221

PP

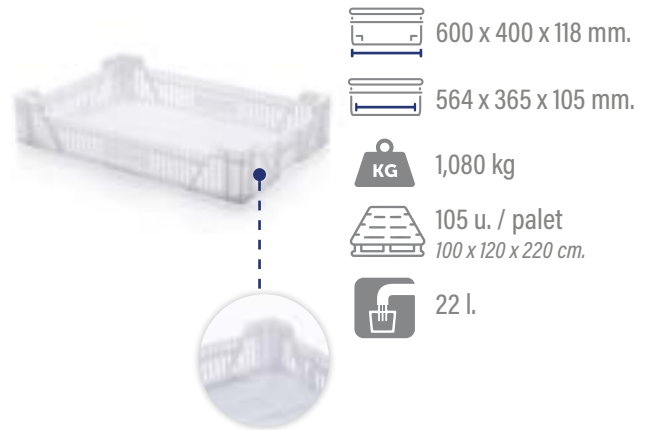

71222

PEAD

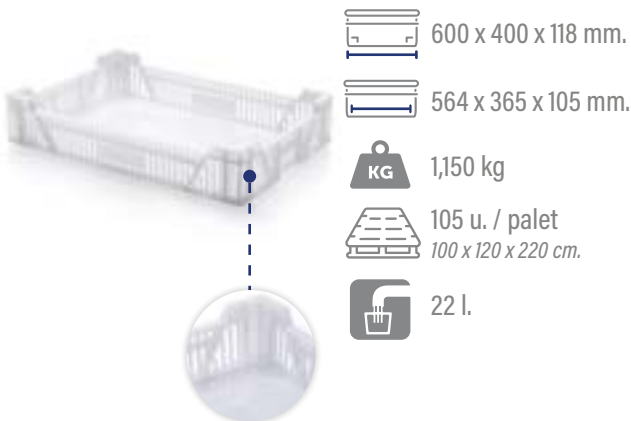

71223

PEAD

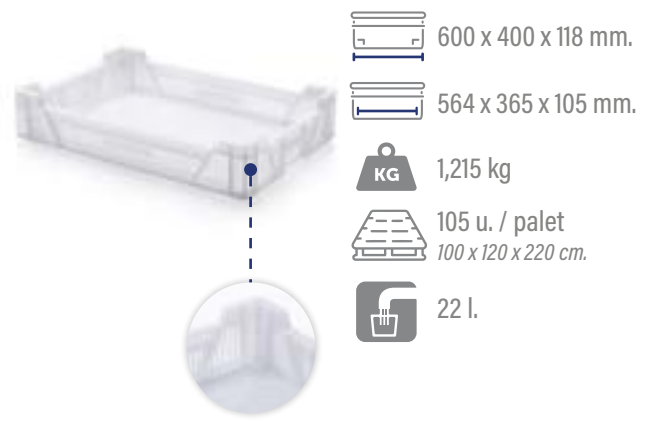

71224

PP





75351

PEAD

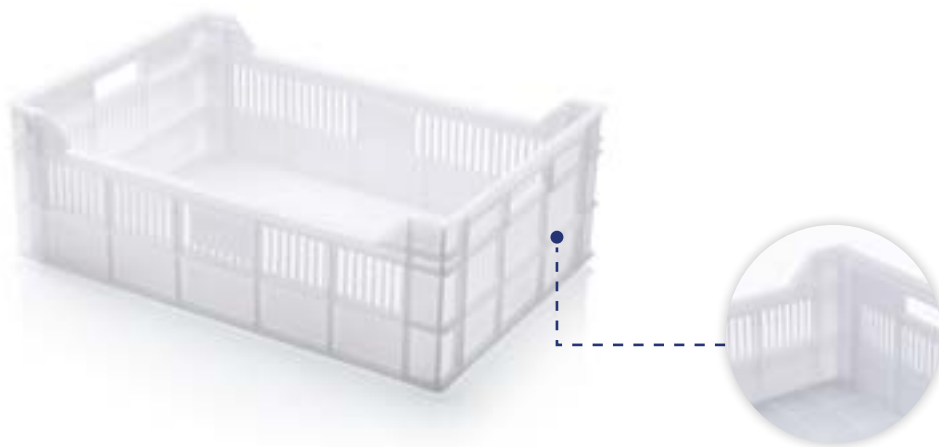
 600 x 400 x 208 mm.

 565 x 365 x 180 mm.

 2,200 kg

 55 u. / palet
100 x 120 x 220 cm

 35 l.

75352

PEAD

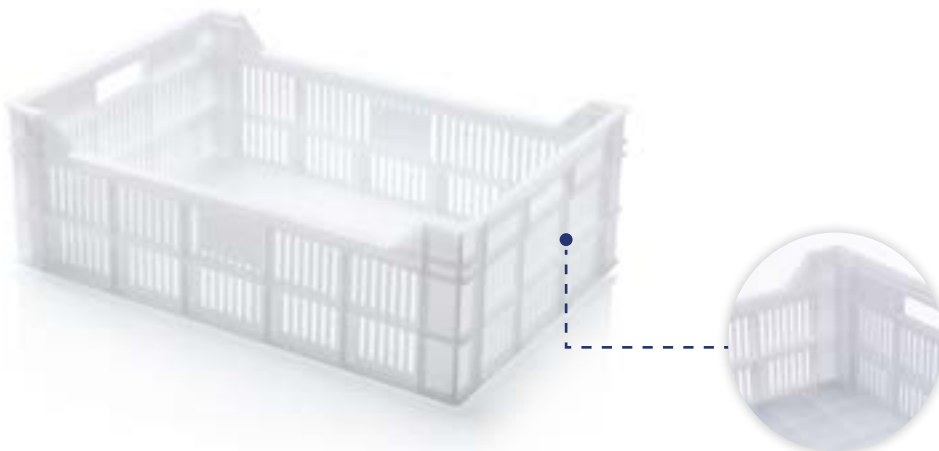
 600 x 400 x 208 mm.

 565 x 365 x 180 mm.

 2,000 kg

 55 u. / palet
100 x 120 x 220 cm.

 35 l.

75353

PEAD

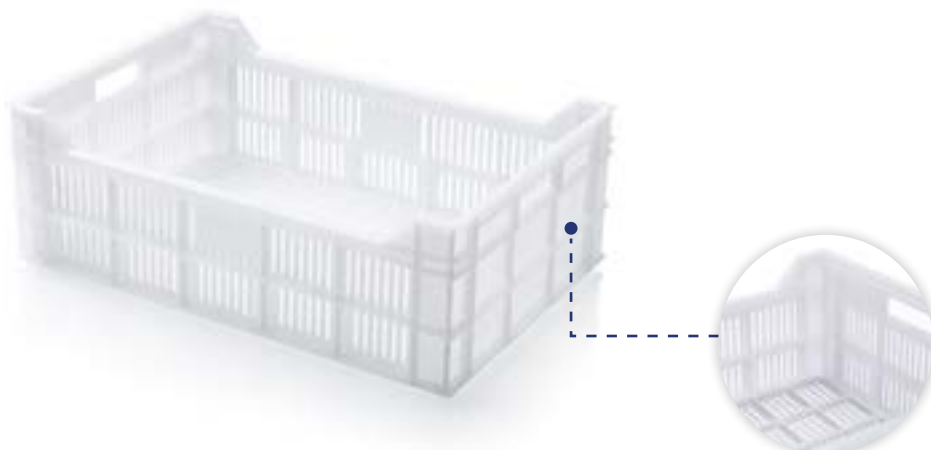
 600 x 400 x 208 mm.

 565 x 365 x 180 mm.

 1,750 kg

 55 u. / palet
100 x 120 x 220 cm.

 35 l.



71401

PEAD



 600 x 400 x 214 mm.

 560 x 362 x 194 mm.

 2,300 kg

 50 u. / palet
100 x 120 x 220 cm.

 40 l.

72645

PP



 800 x 600 mm.

 1,000 kg

 100 u. / palet
100 x 120 x 220 cm.

74450

PP



 800 x 600 x 120 mm.

 748 x 548 x 113 mm.

 4,400 kg

 34 u. / palet
80 x 120 x 220 cm.

 45 l.

74900

PP



 800 x 600 x 220 mm.

 748 x 548 x 216 mm.

 5,750 kg

 20 u. / palet
80 x 120 x 220 cm.

 90 l.

74300

PP



 800 x 600 x 325 mm.

 748 x 548 x 319 mm.

 7,050 kg

 14 u. / palet
80 x 120 x 220 cm.

 130 l.

74570

PP



 800 x 600 x 425 mm.

 748 x 548 x 422 mm.

 8,200 kg

 14 u. / palet
80 x 120 x 220 cm.

 175 l.

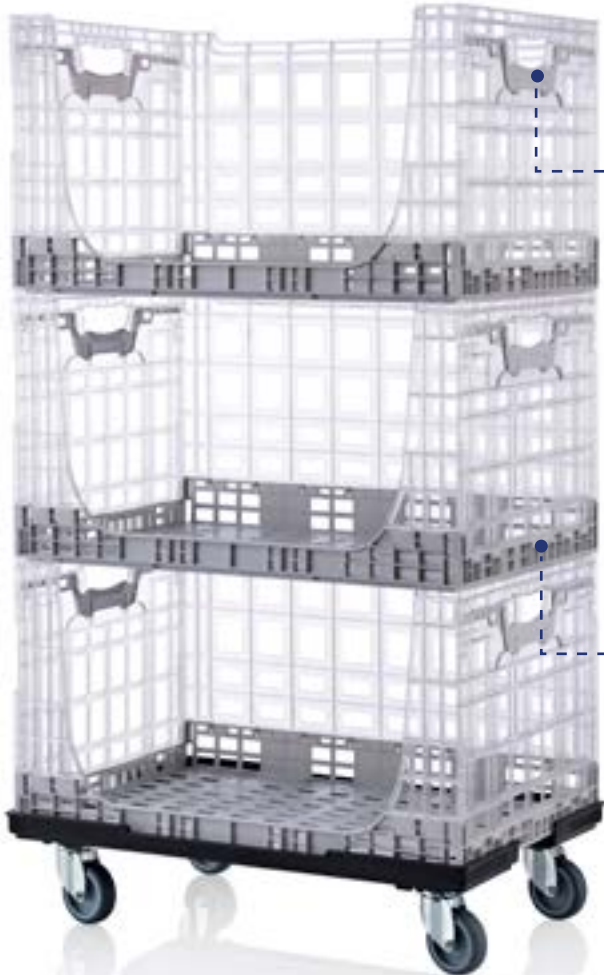

80000

PP

 600 x 400 x 325 mm.

 600 x 400 x 70 mm.

 1,860 kg

 100 u. / palet
80 x 120 x 220 cm.

70720

PP

 600 x 400 x 175 mm.

 1,760 kg

 20 u. / palet
80 x 120 x 220 cm

 100 kg
carga estática / static load

 Ø 75 mm.



85000

PP



600 x 400 x 120 mm.

574 x 371 x 100 mm.

1,385 kg

240 u. / palet
120 x 80 cm

21 l.

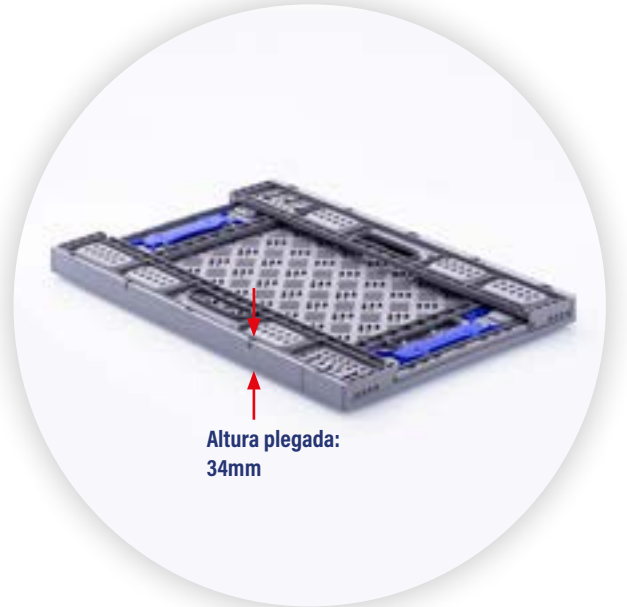

85100

PP



600 x 400 x 180 mm.

574 x 371 x 160 mm.

1,700 kg

240 u. / palet
120 x 80 cm

35 l.



85200

PP



600 x 400 x 220 mm.

574 x 371 x 200 mm.

1,995 kg

240 u. / palet
120 x 80 cm

42 l.

70100

PP

 300 x 270 x 120 mm.

 270 x 240 x 115 mm.

 0,640 kg

 240 u. / palet
100 x 120 x 220 cm.

 7 l.

70190

PEAD

 475 x 405 x 140 mm.

 420 x 370 x 135 mm.

 1,160 kg

 102 u. / palet
100 x 120 x 220 cm.

 18 l.

70250

PEAD

 440 x 314 x 200 mm.

 370 x 270 x 192 mm.

 1,185 kg

 120 u. / palet
100 x 120 x 220 cm.

 20 l.

70910

PEAD

 661 x 454 x 410 mm.

 592 x 406 x 400 mm.

 3,870 kg



 30 u. / palet
100 x 120 x 220 cm.

 90 l.



70320 PEAD







 770 x 490 x 120 mm.  60 u. / palet
 100 x 120 x 220 cm.  30 l.

 **KG** 2,200 kg

75401 PEAD







 500 x 370 x 280 mm.  72 u. / palet
 100 x 120 x 220 cm.  40 l.

 **KG** 1,520 kg

77530 PEAD







 610 x 380 x 340 mm.  50 u. / palet
 100 x 120 x 220 cm.  66 l.

 **KG** 2,300 kg

77100 PEAD



 500 x 370 x 270 mm.  72 u. / palet
 100 x 120 x 220 cm.  41 l.

 **KG** 1,870 kg

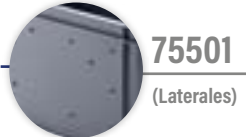

75500 | 75501 | 75502 PEAD



75501
(Laterales)





75502
(Fondo)

 550 x 390 x 295 mm.  48 u. / palet
 100 x 120 x 220 cm.  50 l.

 **KG** 2,870 kg

71800 PEAD



 690 x 590 x 565 mm.  16 u. / palet
 100 x 120 x 220 cm.  180 l.

 **KG** 5,060 kg

CAJAS ENCAJABLES *NESTABLE CRATES*

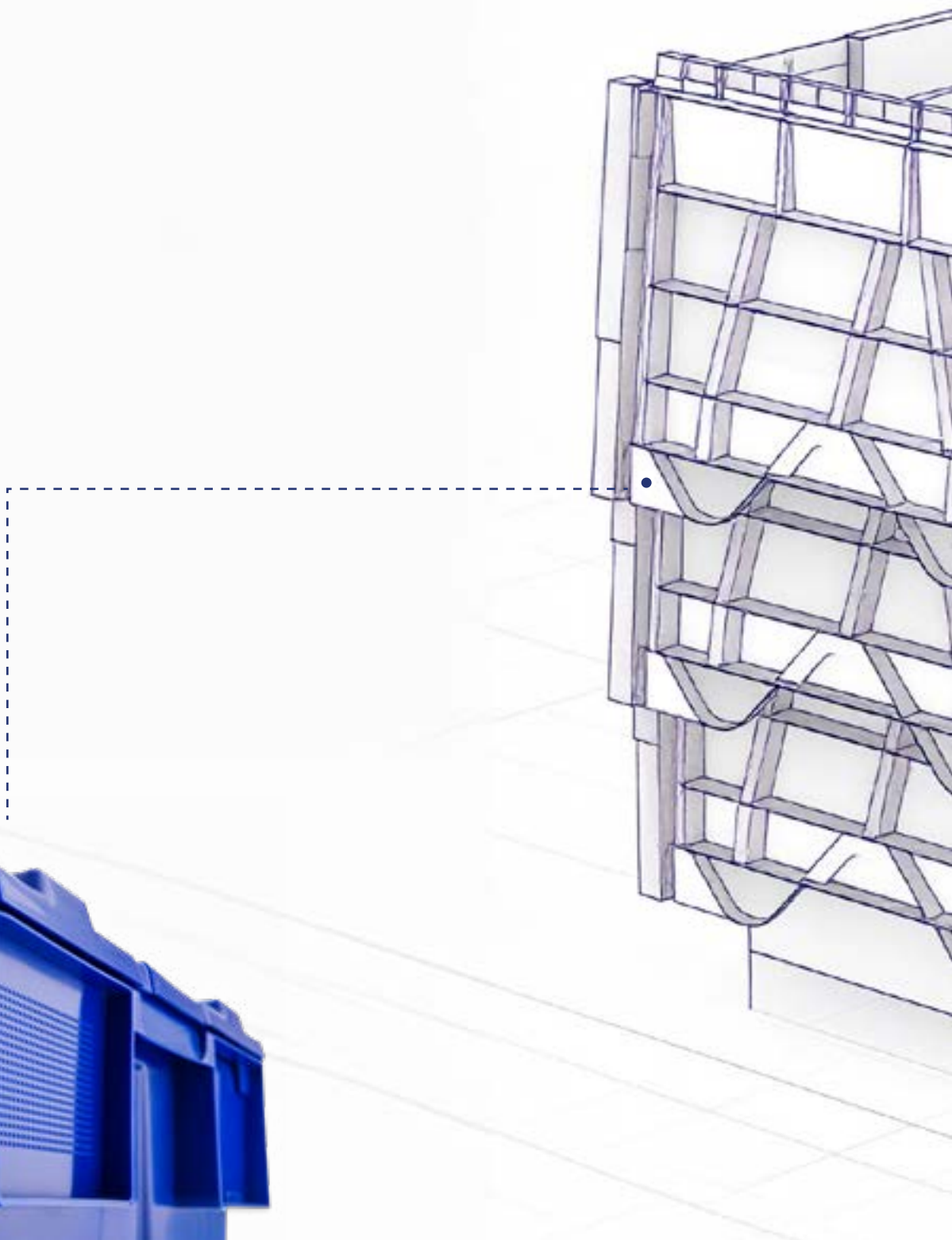

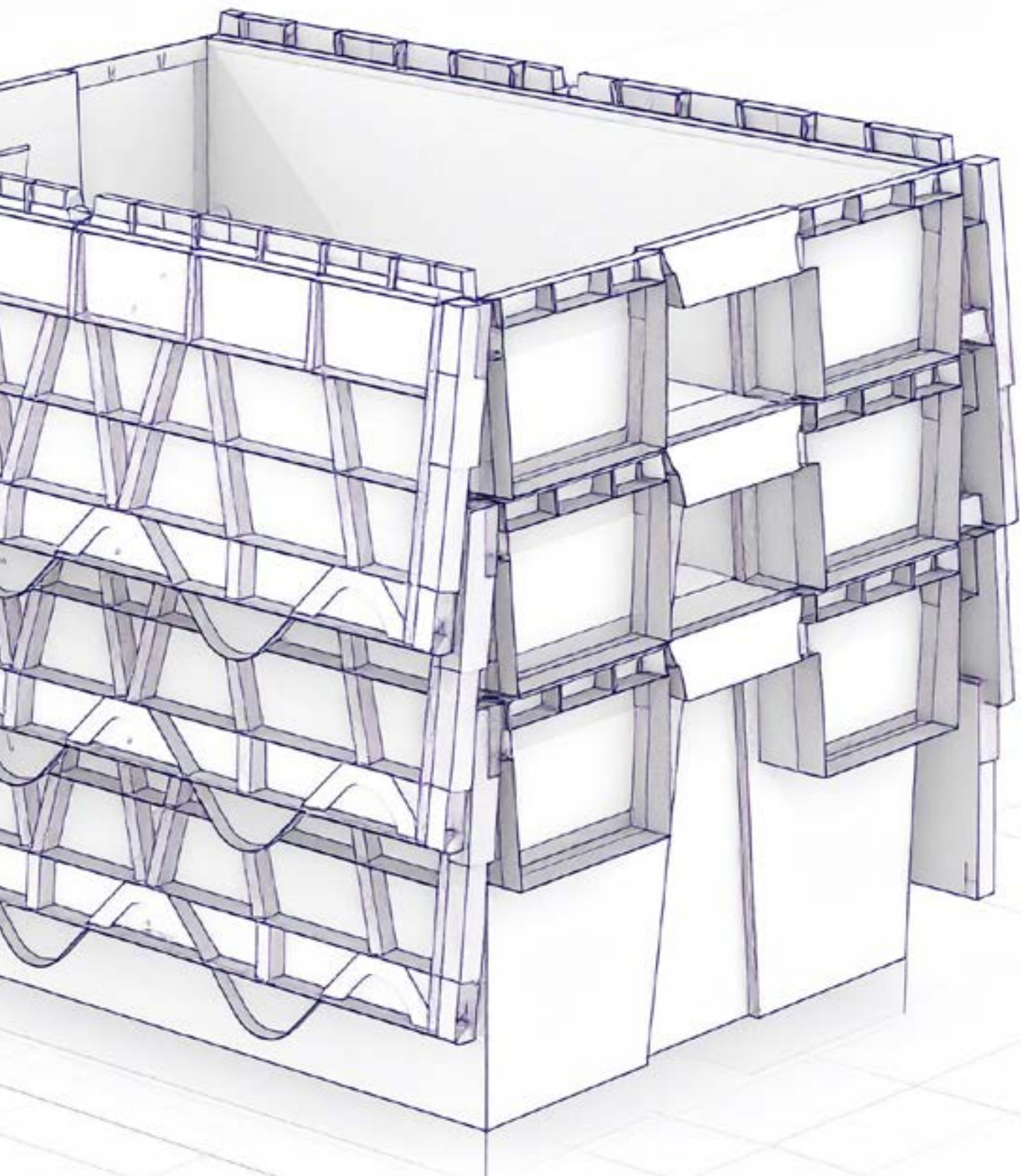



70420

PP



490 x 300 x 160 mm.

408 x 234 x 130 mm.

0,930 kg

 280 u. / palet
100 x 120 x 220 cm

17 l.

70440

PP



490 x 300 x 260 mm.

408 x 234 x 230 mm.

1,215 kg

 280 u. / palet
100 x 120 x 220 cm.

25 l.

70441

PP



500 x 300 mm.

0,516 kg

 280 u. / palet
100 x 120 x 220 cm.



70800

PP



 600 x 400 x 265 mm.

 545 x 370 x 245 mm.

 2,715 kg

 60 u. / palet
110 x 100 x 220 cm.

 45 l.

CAJAS APILABLES Y ENCAJABLES

STACKABLE AND NESTABLE CRATES

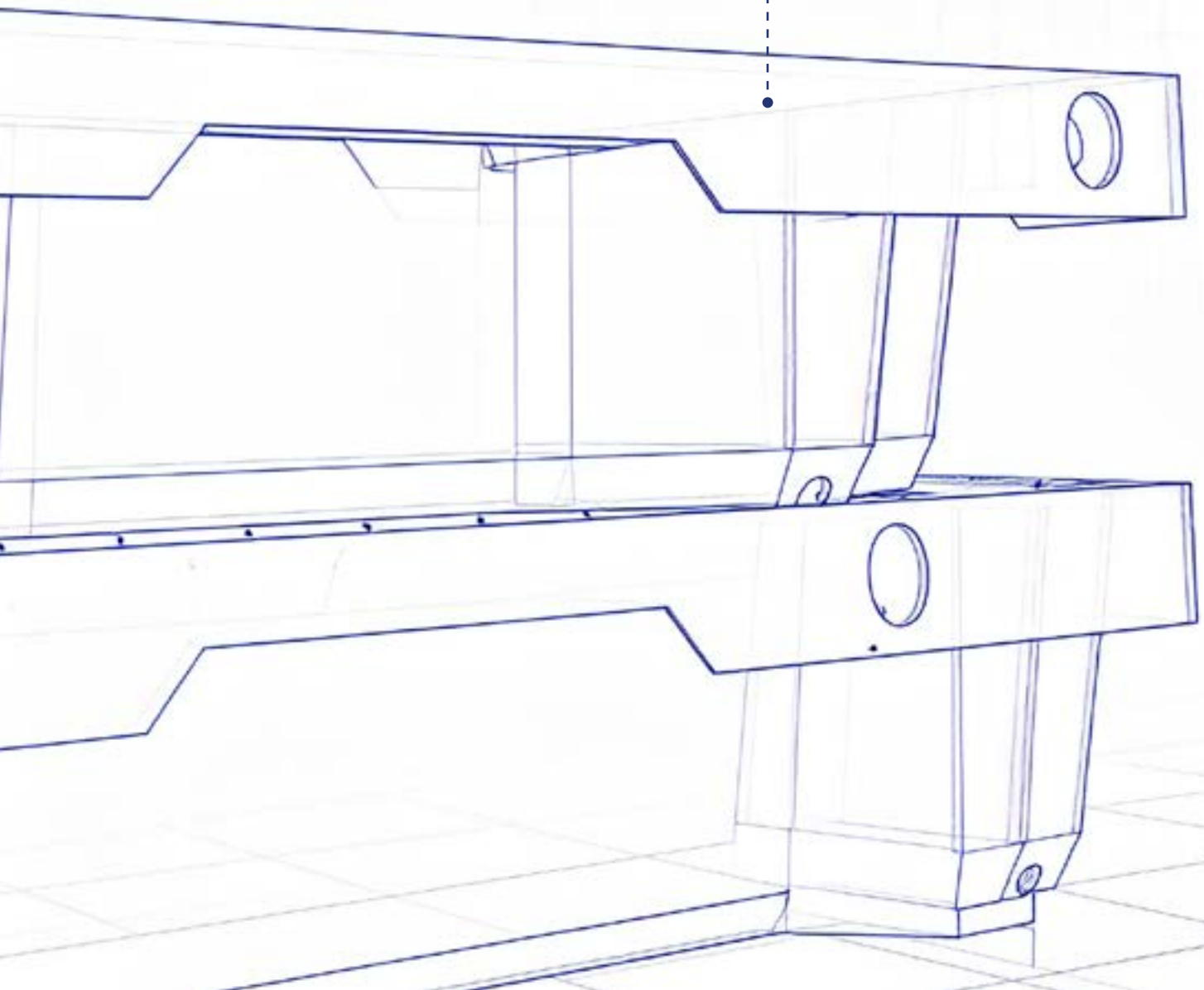



70522 | 70520

PEAD



70520

70522

600 x 400 x 90 mm.

300 u. / palet
100 x 120 x 220 cm

490 x 365 x 75 mm.

13 l.

KG 0,870 kg

70523 | 70521

PEAD



70521

70523

600 x 400 x 90 mm.

300 u. / palet
100 x 120 x 220 cm

490 x 365 x 75 mm.

13 l.

KG 0,870 kg

70540

PEAD

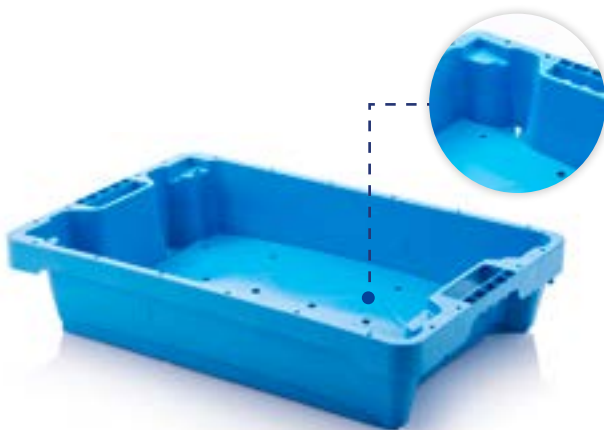

600 x 400 x 125 mm.

200 u. / palet
100 x 120 x 220 cm

465 x 395 x 115 mm.

18 l.

KG 1,420 kg

70541

PEAD

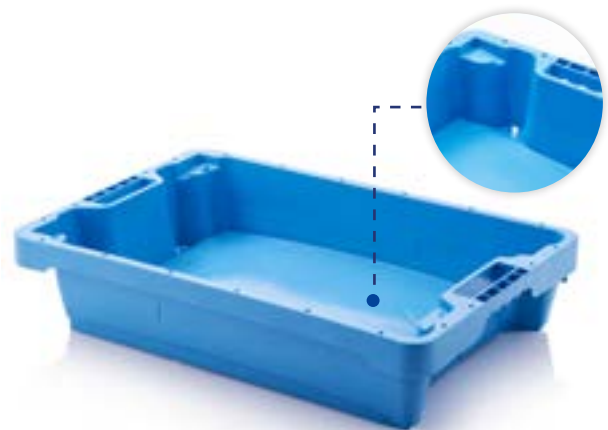

600 x 400 x 125 mm.

200 u. / palet
100 x 120 x 220 cm

465 x 395 x 115 mm.

18 l.

KG 1,420 kg



73120

PEAD

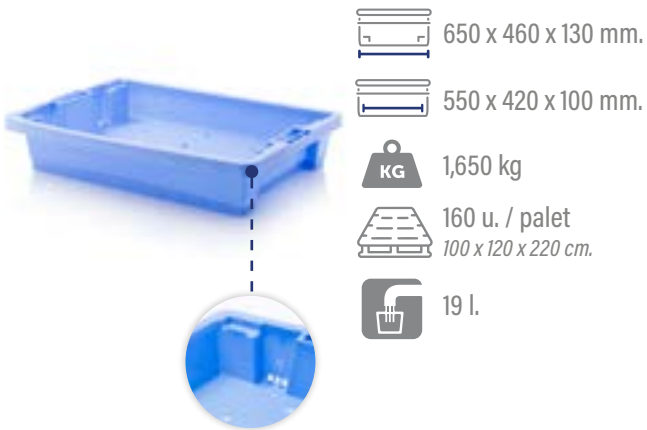

73110

PEAD

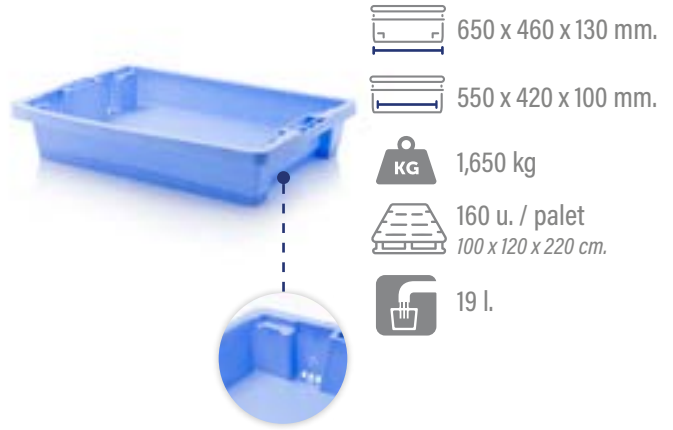

70170

PEAD

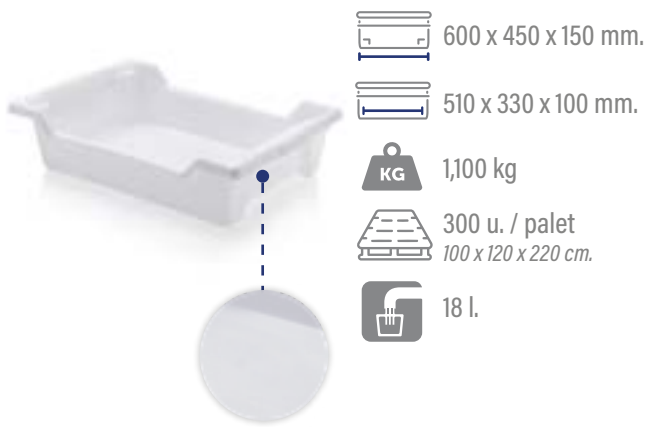

70171

PEAD

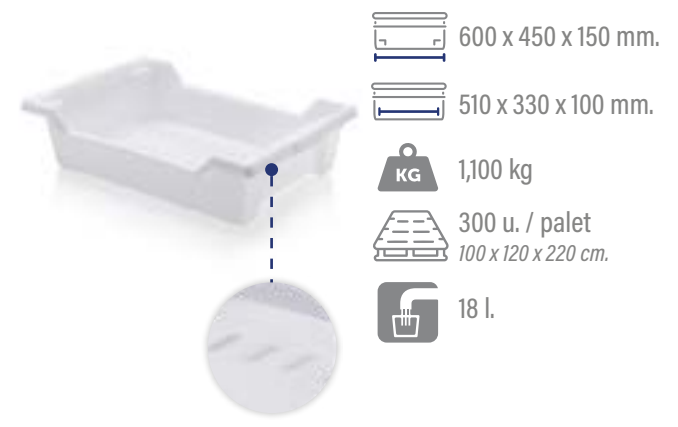

70172

PEAD

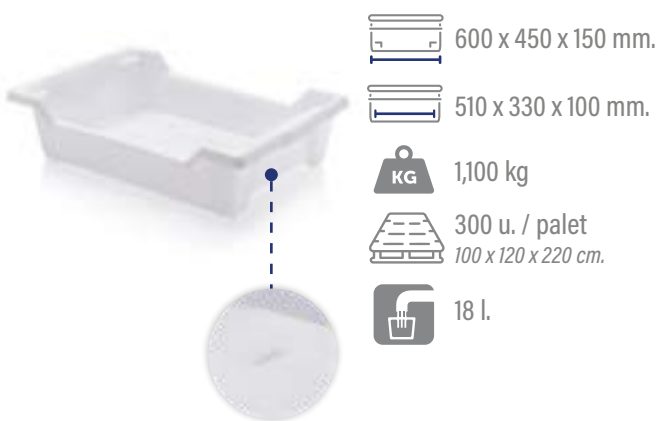



70180

PEAD



510 x 350 x 155 mm.



350 u. / palet
100 x 120 x 220 cm.



365 x 290 x 135 mm.



18 l.



0,980 kg

70330

PEAD



805 x 450 x 155 mm.



105 u. / palet
100 x 120 x 220 cm.



660 x 400 x 148 mm.



30 l.



2,460 kg

70350

PEAD



500 x 400 x 267 mm.



120 u. / palet
100 x 120 x 220 cm.



371 x 339 x 240 mm.



35 l.



1,775 kg

71102

PEAD



510 x 405 mm.



250 u. / palet
100 x 120 x 220 cm.



0,680 kg



75461

PEAD

 600 x 400 x 200 mm.

 550 x 365 x 185 mm.

 1,350 kg

 84 u. / palet
80 x 120 x 220 cm.

 35 l.

75462

PEAD

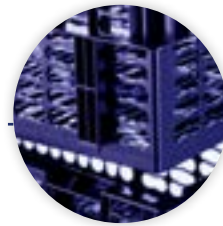
 600 x 400 x 200 mm

 562 x 352 x 185 mm

 1,550 kg

 84 u. / palet
80 x 120 x 220 cm.

 35 l.



75150

PEAD



600 x 400 x 150 mm.

593 x 399 x 147 mm.

1,358 kg

145 u. / palet
100 x 120 x 220 cm

26 l.

75151

PEAD



600 x 400 x 150 mm.

593 x 399 x 147 mm.

1,250 kg

145 u. / palet
100 x 120 x 220 cm

26 l.

75160 | 75200

PEAD



600 x 400 x 200 mm.

566 x 338 x 195 mm.

2,430 kg

84 u. / palet
80 x 120 x 220 cm

35 l.



75160

(Fondo cerrado)



75200

(Fondo rejado)

75161 | 75201

PEAD

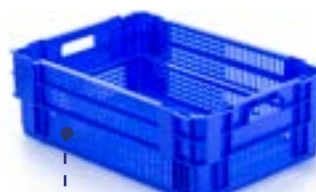

600 x 400 x 200 mm.

566 x 338 x 195 mm.

2,077 kg

84 u. / palet
80 x 120 x 220 cm

35 l.



75161

(Fondo rejado)



75201

(Fondo cerrado)

75360

PEAD



700 x 380 x 185 mm.

625 x 315 x 165 mm.

1,440 kg

100 u. / palet
100 x 120 x 220 cm

36 l.





73010

PEAD



430 x 300 x 90 mm.

400 x 280 x 85 mm.

0,475 kg

 504 u. / palet
100 x 120 x 220 cm.

12 l.

73040

PEAD



400 x 400 x 90 mm.

368 x 360 x 75 mm.

0,580 kg

 378 u. / palet
100 x 120 x 220 cm.

12 l.

73180

PEAD



570 x 300 x 175 mm.

510 x 220 x 150 mm.

1,060 kg

 120 u. / palet
100 x 120 x 220 cm.

16 l.

70260

PEAD



355 x 355 x 285 mm.

313 x 313 x 260 mm.

1,150 kg

 108 u. / palet
100 x 120 x 220 cm.

26 l.

73240

PEAD



740 x 640 x 120 mm.

700 x 600 x 100 mm.

2,223 kg

 50 u. / palet
80 x 120 x 220 cm.

41 l.

70670

PEAD



800 x 600 x 171 mm.

750 x 550 x 150 mm.

2,470 kg

 60 u. / palet
100 x 120 x 220 cm.

62 l.



75430

PEAD



 570 x 370 x 313 mm.

 485 x 308 x 290 mm.

 1,880 kg

 105 u. / palet
100 x 120 x 220 cm.

 40 l.

73130

PEAD



 550 x 380 x 300 mm.

 500 x 330 x 250 mm.

 2,079 kg

 90 u. / palet
100 x 120 x 220 cm.

 42 l.

73140

PEAD



 550 x 380 x 300 mm

 500 x 330 x 250 mm

 2,016 kg

 90 u. / palet
100 x 120 x 220 cm.

 42 l.

75910

PEAD



 920 x 550 x 510 mm.

 850 x 500 x 480 mm.

 6,750 kg

 20 u. / palet
100 x 120 x 220 cm.

 200 l.

73020

PEAD



 600 x 400 x 210 mm.

 550 x 360 x 200 mm.

 1,920 kg

 125 u. / palet
100 x 120 x 220 cm.

 33 l.

73100

PEAD



 600 x 400 x 270 mm.

 575 x 370 x 250 mm.

 2,240 kg

 150 u. / palet
100 x 120 x 220 cm.

 45 l.

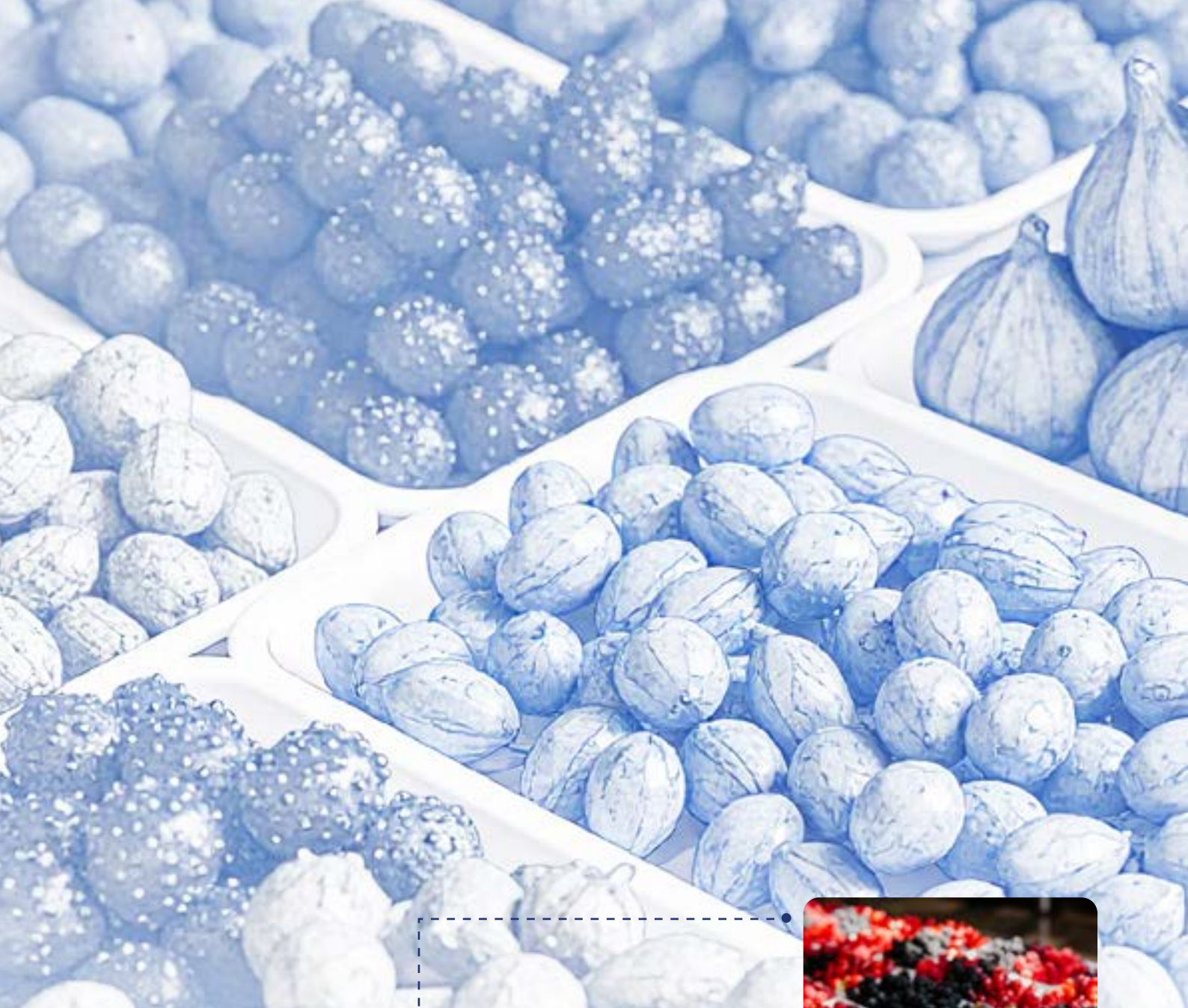

**BANDEJAS DE
EXPOSICIÓN Y
CONSERVACIÓN**

*TRAYS DISPLAY AND
PRESERVATION*





11710

PEAD



 300 x 210 x 65 mm.

 0,210 kg

 1092 u. / palet
80 x 120 x 225 cm.

 2 l.

 6 u. / caja

11720

PEAD



 340 x 235 x 70 mm.

 0,275 kg

 780 u. / palet
80 x 120 x 225 cm.

 3 l.

 6 u. / caja

11730

PEAD



 430 x 285 x 75 mm.

 0,410 kg

 432 u. / palet
80 x 120 x 225 cm.

 6 l.

 6 u. / caja

11740

PEAD



 480 x 330 x 80 mm.

 0,580 kg

 288 u. / palet
80 x 120 x 225 cm.

 8 l.

 6 u. / caja

11750

PEAD



 535 x 385 x 85 mm.

 0,800 kg

 264 u. / palet
80 x 120 x 225 cm.

 12 l.

 6 u. / caja

CUBOS Y BARREÑOS



BINS AND BUCKETS

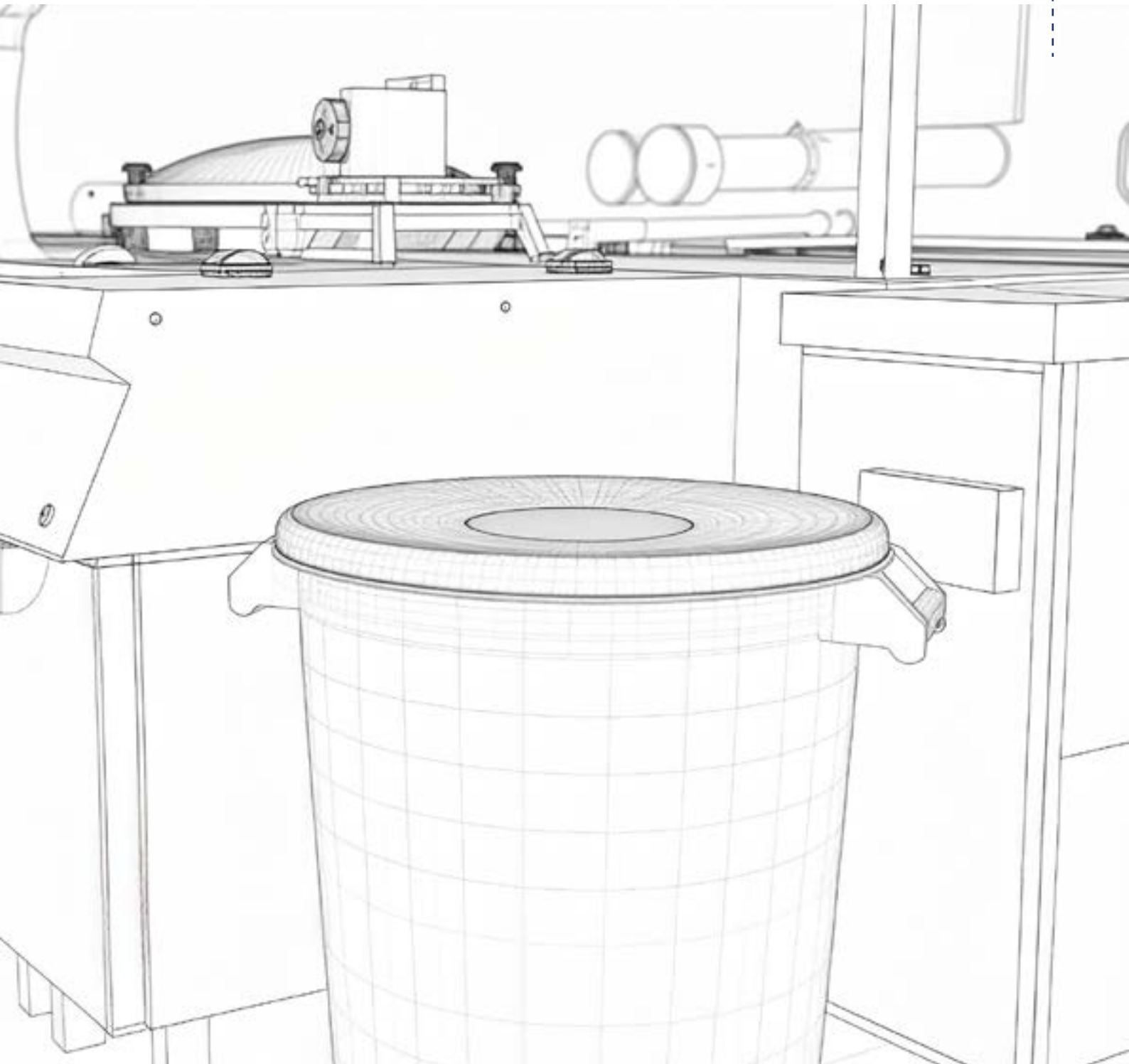



13255

PEAD



 Ø 455 x 505 mm.

 2,067 kg

 100 u. / palet
80 x 120 x 225 cm.

 50 l.

13265

PEAD



 Ø 495 x 585 mm.

 2,576 kg

 80 u. / palet
80 x 120 x 225 cm.

 70 l.

23180

PEAD



 Ø 495 x 730 mm.

 3,614 kg

 60 u. / palet
80 x 120 x 225 cm.

 95 l.

23188

PEAD



 Ø 370 x 85 mm.

 2,175 kg

 50 u. / palet
80 x 120 x 225 cm.

23110

PEAD



 Ø 515 x 670 mm.

 4,122 kg

 60 u. / palet
80 x 120 x 225 cm.

 100 l.

23108

PEAD



 Ø 480 x 105 mm.

 2,960 kg

 50 u. / palet
80 x 120 x 225 cm.

13030

PEAD



Ø 290 x 262 mm.

360 u. / palet
80 x 120 x 225 cm.

0,383 kg



10 l.

13040

PEAD



Ø 310 x 280 mm.

330 u. / palet
80 x 120 x 225 cm.

0,483 kg



12 l.

13050

PEAD



Ø 340 x 305 mm.

240 u. / palet
80 x 120 x 225 cm.

0,683 kg



15 l.

13060

PEAD



Ø 360 x 335 mm.

180 u. / palet
80 x 120 x 225 cm.

0,817 kg



20 l.

**13140****PP** Ø 335 x 160 mm. **KG** 0,333 kg 432 u. / palet
80 x 120 x 225 cm. 10 l.**13150****PP** Ø 380 x 180 mm. **KG** 0,525 kg 288 u. / palet
80 x 120 x 225 cm. 15 l.**13160****PP** Ø 440 x 205 mm. **KG** 0,625 kg 180 u. / palet
80 x 120 x 225 cm. 20 l.**13170****PP** Ø 490 x 230 mm. **KG** 0,888 kg 144 u. / palet
80 x 120 x 225 cm. 30 l.**13180****PP** Ø 535 x 250 mm. **KG** 1,090 kg 90 u. / palet
80 x 120 x 225 cm. 35 l.**23060****PP** 310 x 310 x 170 mm. **KG** 0,405 kg 432 u. / palet
80 x 120 x 225 cm. 8 l.

CONTENEDORES INDUSTRIALES

INDUSTRIAL CONTAINERS

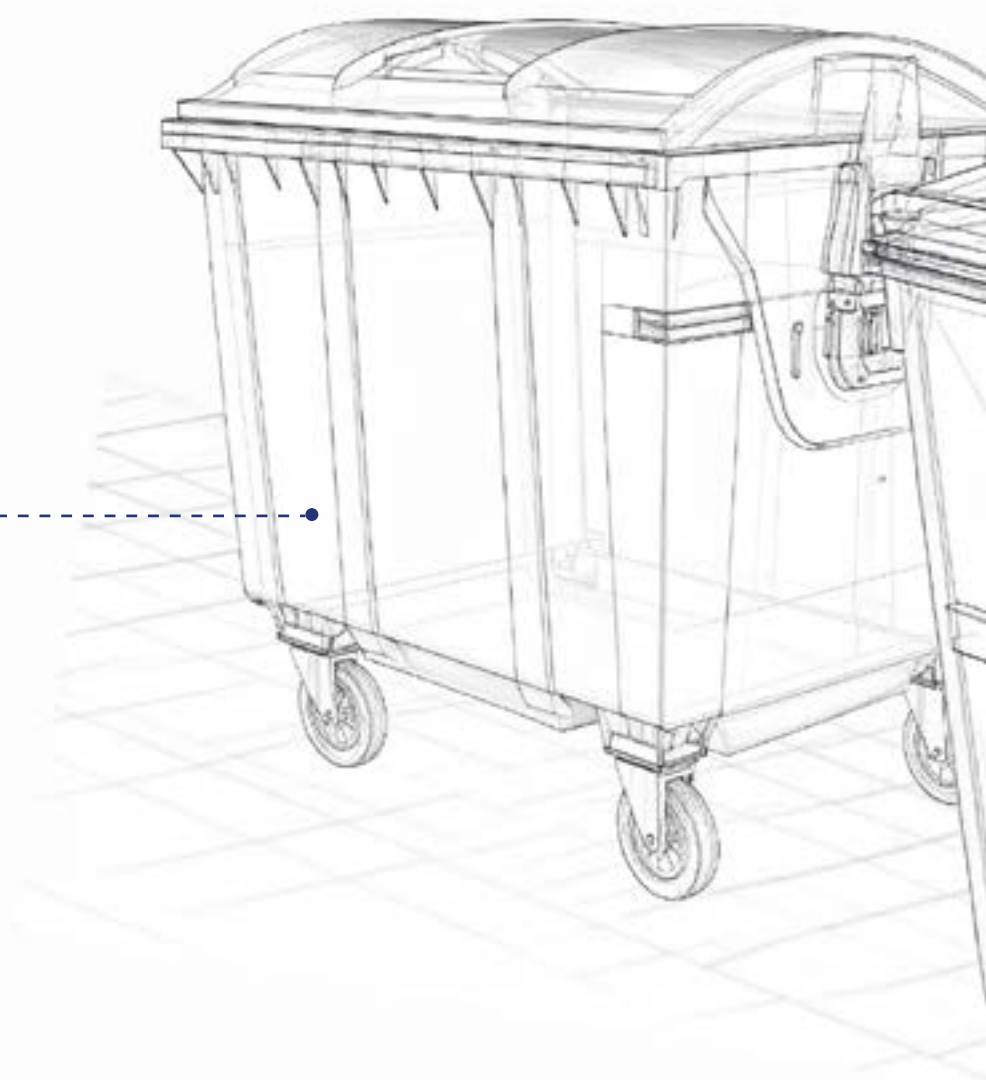





79080 | 79085

PEAD



450 x 550 x 940 mm.

8,500 kg

10 u. / palet
100 x 80 x 240 cm

80 l.

79120 | 79125

PEAD



480 x 530 x 950 mm.

7,500 kg

10 u. / palet
100 x 80 x 240 cm

120 l.

79240 | 79245

PEAD



580 x 705 x 1050 mm.

11,000 kg

10 u. / palet
100 x 80 x 240 cm

240 l.

79360 | 79365

PEAD



620 x 865 x 1114 mm.

14,140 kg

7 u. / palet
100 x 80 x 240 cm

360 l.



79751

PEAD



 1360 x 778 x 1320 mm.

 37,400 kg

 4 u. / palet
100 x 80 x 240 cm

 800 l.

79130

PEAD



 1370 x 1100 x 1330 mm.

 50,920 kg

 3 u. / palet
100 x 80 x 240 cm.

 1100 l.

79131

PEAD



 1370 x 1100 x 1330 mm.

 50,92 kg

 3 u. / palet
100 x 80 x 240 cm.

 1100 l.

GRANDES CONTENEDORES

*LARGE CONTAINERS
AND PALLETS*

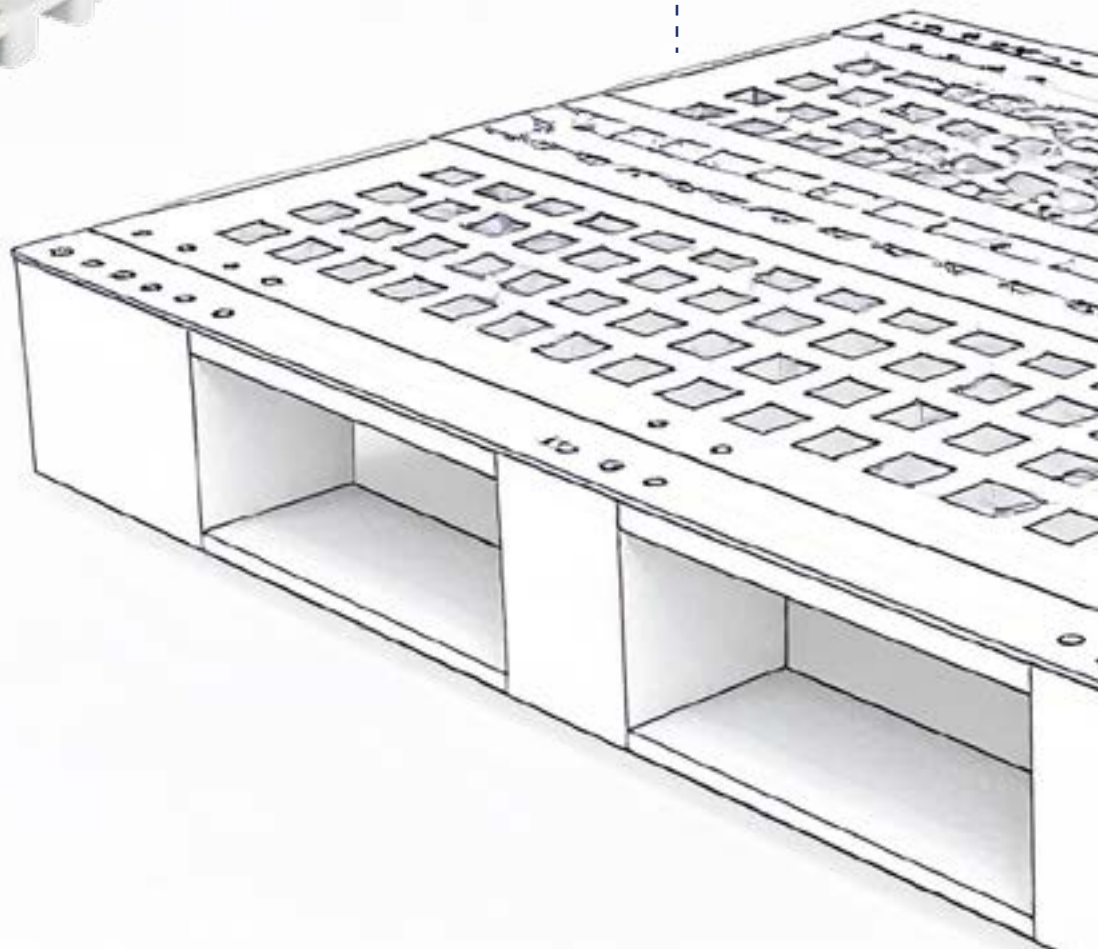

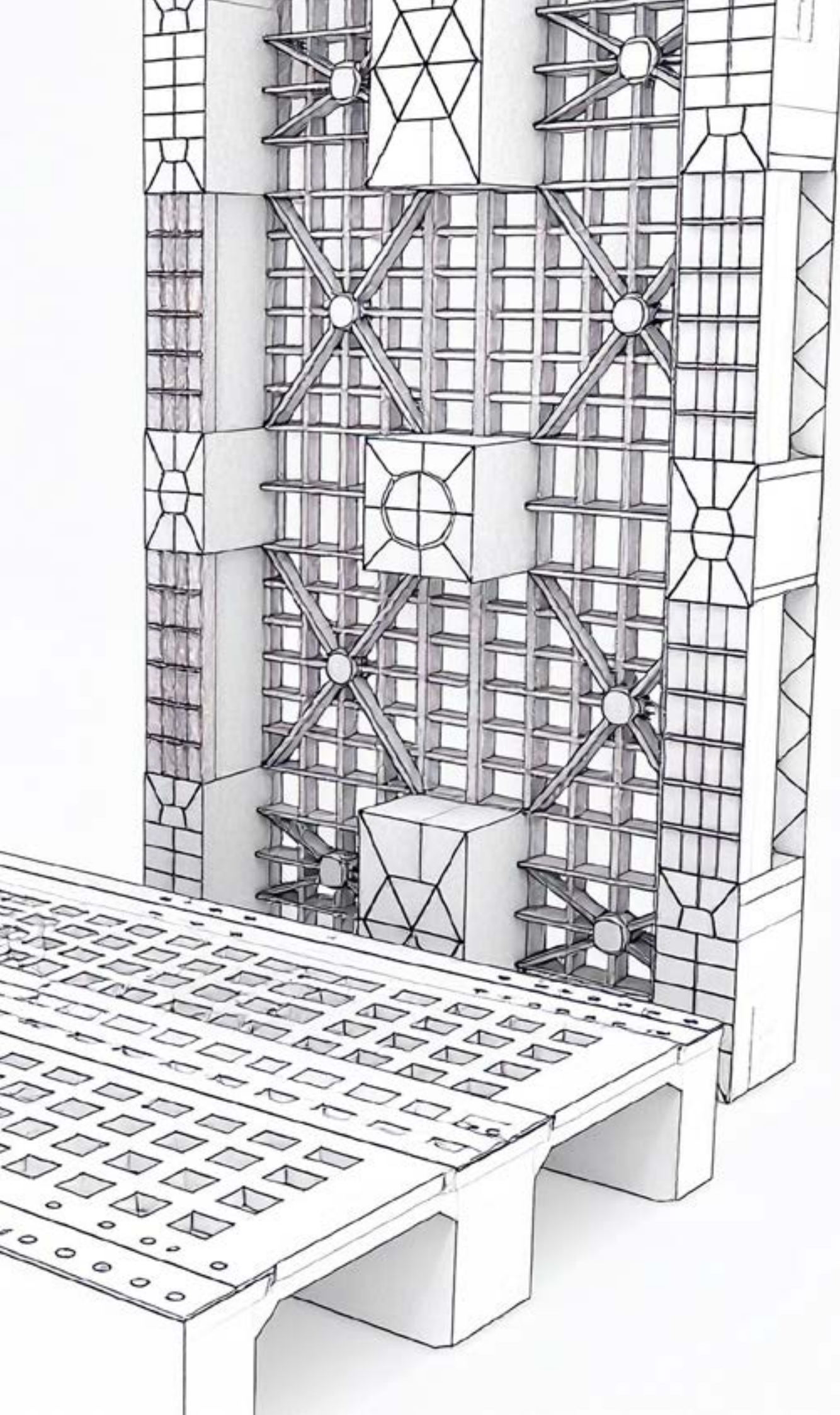



79307

PEAD



1000 x 635 x 645 mm.

4 u. / pila
100 x 80 x 240 cm

925 x 580 x 520 mm.



300 l.



11,800 kg

79317

PEAD



1200 x 800 x 600 mm.

4 u. / pila
100 x 80 x 240 cm

1118 x 718 x 446 mm.



350 l.



23,880 kg

79617

PEAD



1200 x 800 x 800 mm.

3 u. / pila
100 x 80 x 240 cm

1118 x 718 x 646 mm.



525 l.



29,460 kg

79515

PEAD



1200 x 1000 x 580 mm.

4 u. / pila
100 x 120 x 240 cm

1110 x 910 x 425 mm.



450 l.



31,370 kg



79730

PEAD



 1200 x 1000 x 760 mm.

 1120 x 920 x 600 mm.

 31,210 kg

 4 u. / pila
100 x 120 x 240 cm.

 610 l.

79731

PEAD



 1200 x 1000 x 760 mm.

 1120 x 920 x 600 mm.

 30,56 kg

 4 u. / pila
100 x 120 x 240 cm.

 610 l.

79740

PEAD



 1225 x 1025 x 75 mm.

 6,510 kg

 40 u. / pila
100 x 120 x 240 cm.

79741

PEAD



 1215 x 816 x 75 mm.

 5,990 kg

 40 u. / pila
100 x 120 x 240 cm.

79743

PEAD



 1012 x 654 x 75 mm.

 3,800 kg

 40 u. / pila
100 x 80 x 240 cm.



72032

PPr

 1200 x 800 x 134 mm. 48 u. / palet
120 x 80 x 240 cm 12,100 kg

72033

PPr

 1200 x 800 x 134 mm. 48 u. / palet
120 x 80 x 240 cm 6,000 kg

72091

PPr

 1200 x 800 x 150 mm. 17 u. / palet
100 x 80 x 240 cm. 12,100 kg 610 l.

72092

PPr

 1200 x 800 x 150 mm. 17 u. / palet
100 x 80 x 240 cm. 14,000 kg 770 l.



72042

PEAD



1200 x 800 x 160 mm.



16 u. / palet
100 x 80 x 240 cm.



18,000 kg

72040

PEAD



1200 x 800 x 160 mm.



16 u. / palet
100 x 80 x 240 cm.



18,000 kg

72095

PPr



1200 x 1000 mm.



17 u. / pila
100 x 80 x 240 cm.



17,5 kg

72096

PPr



1200 x 1000 mm.



17 u. / pila
100 x 80 x 240 cm.



18,5 kg

ÍNDICE POR REFERENCIAS / REFERENCE INDEX

Referencia Reference	Material Material	Largo (mm) Length (mm)	Ancho (mm) Width (mm)	Alto (mm) Height (mm)	Peso (kg) Weight (kg)	Ud. por pallet Units	Capacidad l. Capacity l.	Página Page
aa11710	PEAD	300	210	65	0,21	1092	2	35
bb11720	PEAD	340	235	70	0,28	780	3	35
11730	PEAD	430	285	75	0,41	432	6	35
11740	PEAD	480	330	80	0,58	288	8	35
11750	PEAD	535	385	85	0,80	264	12	35
13030	PEAD	Ø290		262	0,48	360	10	38
13040	PEAD	Ø310		280	0,48	330	12	38
13050	PEAD	Ø340		305	0,68	240	15	38
13060	PEAD	Ø360		335	0,83	180	20	38
13140	PP	Ø335		160	0,33	432	10	39
13150	PP	Ø380		180	0,53	288	15	39
13160	PP	Ø440		205	0,63	180	20	39
13170	PP	Ø490		230	0,89	144	30	39
13180	PP	Ø535		250	1,09	90	35	39
13255	PEAD	Ø455		505	2,07	100	50	37
13265	PEAD	Ø495		585	2,58	80	70	37
23060	PP	310	310	170	0,41	432	8	39
23108	PEAD	Ø480		105	2,96	50		37
23110	PEAD	Ø515		670	4,12	60	100	37
23180	PEAD	Ø495		730	3,61	60	95	37
23188	PEAD	Ø370		85	2,18	50		37
70100	PP	300	270	120	0,64	240	7	20
70119	PEAD	400	400	80	0,84	150	12	13
70120	PEAD	600	400	64	0,84	164	12	13
70122	PEAD	600	400	100	1,31	148	19	13
70130	PP	646	445	81	1,31	160	18	13
70170	PEAD	600	450	150	1,10	300	18	28
70171	PEAD	600	450	150	1,10	300	18	28
70172	PEAD	600	450	150	1,10	300	18	28
70180	PEAD	510	350	155	0,98	350	18	29
70190	PEAD	475	405	140	1,16	102	18	20
70250	PEAD	440	314	200	1,19	120	20	20
70260	PEAD	355	355	285	1,15	108	26	32
70300	PEAD	400	300	120	0,75	170	10	8
70320	PEAD	770	490	120	2,20	60	30	21
70330	PEAD	805	450	155	2,46	105	30	29
70350	PEAD	500	400	267	1,78	120	35	29
70360	PEAD	600	400	120	1,43	85	23	9
70370	PEAD	600	400	170	1,80	70	30	9
70371	PEAD	600	400	170	1,68	70	30	9
70380	PEAD	600	400	230	1,88	45	45	9
70381	PEAD	600	400	230	1,54	45	45	9
70382	PEAD	600	400	230	1,88	45	45	9
70383	PEAD	600	400	230	1,54	45	45	9
70400	PEAD	400	300	230	1,02	90	20	8
70401	PEAD	400	300	230	1,02	90	20	8

Referencia <i>Reference</i>	Material <i>Material</i>	Largo (mm) <i>Length (mm)</i>	Ancho (mm) <i>Width (mm)</i>	Alto (mm) <i>Height (mm)</i>	Peso (kg) <i>Weight (kg)</i>	Ud. por pallet <i>Units</i>	Capacidad l. <i>Capacity l.</i>	Página <i>Page</i>
70410	PEAD	400	300	175	0,90	140	15	8
70411	PEAD	400	300	175	0,90	140	15	8
70420	PP	490	300	160	0,93	280	17	24
70430	PEAD	400	300	325	1,48	70	30	8
70431	PEAD	400	300	325	1,48	70	30	8
70440	PP	490	300	260	1,22	280	25	24
70441	PP	500	300		0,52	280		24
70520	PEAD	600	400	90	0,87	300	13	27
70521	PEAD	600	400	90	0,87	300	13	27
70522	PEAD	600	400	90	0,87	300	13	27
70523	PEAD	600	400	90	0,87	300	13	27
70540	PEAD	600	400	125	1,42	200	18	27
70541	PEAD	600	400	125	1,42	200	18	27
70560	PP	625	425	123	1,99	72	28	12
70562	PP	625	425	145	2,15	72	28	12
70660	PEAD	600	400	325	2,90	35	60	10
70661	PEAD	600	400	325	2,49	35	60	10
70670	PEAD	800	600	171	2,47	60	62	32
70710	PP	600	400	175	3,50	48		11
70720	PP	600	400	175	1,76	48		11
70750	ABS	600	400	140	2,60	48		11
70751	PP	600	400	170	3,00	48		11
70800	PP	600	400	265	2,72	60	45	25
70910	PEAD	661	454	410	3,87	30	90	20
70920	PEAD	600	400	425	3,65	25	90	10
70921	PEAD	600	400	425	3,10	25	90	10
71102	PEAD	510	405		0,68	250		29
71110	PP	600	400		0,63	200		10
71220	PEAD	600	400	118	1,08	105	22	15
71221	PP	600	400	118	1,08	105	22	15
71222	PEAD	600	400	118	1,15	105	22	15
71223	PEAD	600	400	118	1,22	105	22	15
71224	PP	600	400	118	1,22	105	22	15
71401	PEAD	600	400	214	2,30	50	40	17
71800	PEAD	690	590	565	5,06	16	180	21
72032	PPr	1200	800	134	5,00	48		48
72033	PPr	1200	800	134	6,00	48		48
72040	PEAD	1200	800	160	18,00	16		49
72042	PEAD	1200	800	160	18,00	16		49
72091	PPr	1200	800	150	12,10	17		48
72092	PPr	1200	800	150	14,00	17		48
72095	PPr	1200	1000		17,50	17		49
72096	PPr	1200	1000		18,50	17		49
72645	PP	800	600		1,00	100		17
72651	PP	400	300	16,5	0,28	1280		8
72662	PP	600	400		0,69	208		10
73010	PEAD	430	300	90	0,48	504	12	32
73020	PEAD	600	400	210	1,92	125	33	33
73040	PEAD	400	400	90	0,58	378	12	32
73050	PEAD	600	400	120	1,26	100	26	14
73060	PEAD	600	400	170	1,58	65	32	14
73100	PEAD	600	400	270	2,24	150	45	33
73110	PEAD	650	460	130	1,65	160	19	28
73120	PEAD	650	460	130	1,65	160	19	28
73130	PEAD	550	380	300	2,08	90	42	33

Referencia Reference	Material Material	Largo (mm) Length (mm)	Ancho (mm) Width (mm)	Alto (mm) Height (mm)	Peso (kg) Weight (kg)	Ud. por pallet Units	Capacidad l. Capacity l.	Página Page
73140	PEAD	550	380	300	2,02	90	42	33
73160	PEAD	600	400	230	1,85	40	44	14
73180	PEAD	570	300	175	1,06	120	16	32
73240	PEAD	740	640	120	2,22	50	41	32
73270	PEAD	600	400	72	1,00	180	14	13
73271	PEAD	600	400	72	0,89	180	14	13
74300	PP	800	600	325	7,05	14	130	17
74450	PP	800	600	120	4,40	34	45	17
74570	PP	800	600	425	8,20	14	175	17
74900	PP	800	600	220	5,75	20	90	17
75150	PEAD	600	400	150	1,36	145	26	31
75151	PEAD	600	400	150	1,25	145	26	31
75160	PEAD	600	400	200	2,43	84	35	31
75161	PEAD	600	400	200	2,08	84	35	31
75200	PEAD	600	400	200	2,44	84	35	31
75201	PEAD	600	400	200	2,10	84	35	31
75351	PEAD	600	400	208	2,20	55	35	16
75352	PEAD	600	400	208	2,00	55	35	16
75353	PEAD	600	400	208	1,75	55	35	16
75360	PEAD	700	380	185	1,44	100	36	31
75401	PEAD	500	370	280	1,52	48	40	21
75430	PEAD	570	370	313	1,88	105	40	33
75461	PEAD	600	400	200	1,35	84	35	30
75462	PEAD	600	400	200	1,55	84	35	30
75500	PEAD	550	390	295	2,87	48	50	21
75501	PEAD	550	390	295	2,87	48	50	21
75502	PEAD	550	390	295	2,87	48	50	21
75910	PEAD	920	550	510	6,75	20	200	33
77100	PEAD	500	370	270	1,87	72	41	21
77530	PEAD	610	380	340	2,30	50	66	21
79080	PEAD	450	550	940	8,50	10	80	42
79085	PEAD	450	550	940	8,50	10	80	42
79120	PEAD	480	530	950	7,50	10	120	42
79125	PEAD	480	530	950	7,50	10	120	42
79130	PEAD	1370	1100	1330	50,92	3	1100	43
79131	PEAD	1370	1100	1330	50,92	3	1100	43
79240	PEAD	580	705	1050	11,00	10	240	42
79245	PEAD	580	705	1050	11,00	10	240	42
79307	PEAD	1000	635	645	11,80	4	300	46
79317	PEAD	1200	800	600	23,80	4	350	46
79360	PEAD	620	865	1114	14,14	10	360	42
79365	PEAD	620	865	1114	14,14	10	360	42
79515	PEAD	1200	1000	580	31,37	4	450	46
79617	PEAD	1200	800	800	29,46	3	525	46
79730	PEAD	1200	1000	760	31,21	4	610	47
79731	PEAD	1120	920	600	30,56	4	610	47
79740	PEAD	1225	1025	75	6,51	40		47
79741	PEAD	1215	816	75	5,99	40		47
79743	PEAD	1012	654	75	3,80	40		47
79751	PEAD	1360	778	1320	37,40	4	800	43
80000	PP	600	400	325	1,86	100		18
85000	PP	600	400	120	1,39	240	21	19
85100	PP	600	400	180	1,70	240	35	19
85200	PP	600	400	220	2,00	240	42	19

ÍNDICE POR MEDIDAS / MEASUREMENT INDEX

Referencia Reference	Material Material	Largo (mm) Length (mm)	Ancho (mm) Width (mm)	Alto (mm) Height (kg)	Peso (kg) Weight (kg)	Ud. por pallet Units	Capacidad l. Capacity l.	Página Page
11710	PEAD	300	210	65	0,21	1092	2	35
70100	PP	300	270	120	0,64	240	7	20
23060	PP	310	310	170	0,41	432	8	39
11720	PEAD	340	235	70	0,28	780	3	35
70260	PEAD	355	355	285	1,15	108	26	32
72651	PP	400	300	16,5	0,28	1280		8
70300	PEAD	400	300	120	0,75	170	10	8
70410	PEAD	400	300	175	0,90	140	15	8
70411	PEAD	400	300	175	0,90	140	15	8
70400	PEAD	400	300	230	1,02	90	20	8
70401	PEAD	400	300	230	1,02	90	20	8
70430	PEAD	400	300	325	1,48	70	30	8
70431	PEAD	400	300	325	1,48	70	30	8
70119	PEAD	400	400	80	0,84	150	12	13
73040	PEAD	400	400	90	0,58	378	12	32
11730	PEAD	430	285	75	0,41	432	6	35
73010	PEAD	430	300	90	0,48	504	12	32
70250	PEAD	440	314	200	1,19	120	20	20
79080	PEAD	450	550	940	8,50	10	80	42
79085	PEAD	450	550	940	8,50	10	80	42
70190	PEAD	475	405	140	1,16	102	18	20
11740	PEAD	480	330	80	0,58	288	8	35
79120	PEAD	480	530	950	7,50	10	120	42
79125	PEAD	480	530	950	7,50	10	120	42
70420	PP	490	300	160	0,93	280	17	24
70440	PP	490	300	260	1,22	280	25	24
70441	PP	500	300		0,52	280		24
77100	PEAD	500	370	270	1,87	72	41	21
75401	PEAD	500	370	280	1,52	48	40	21
70350	PEAD	500	400	267	1,78	120	35	29
70180	PEAD	510	350	155	0,98	350	18	29
71102	PEAD	510	405		0,68	250		29
11750	PEAD	535	385	85	0,80	264	12	35
73130	PEAD	550	380	300	2,08	90	42	33
73140	PEAD	550	380	300	2,02	90	42	33
75500	PEAD	550	390	295	2,87	48	50	21
75501	PEAD	550	390	295	2,87	48	50	21
75502	PEAD	550	390	295	2,87	48	50	21
73180	PEAD	570	300	175	1,06	120	16	32
75430	PEAD	570	370	313	1,88	105	40	33
79240	PEAD	580	705	1050	11,00	10	240	42
79245	PEAD	580	705	1050	11,00	10	240	42
70120	PEAD	600	400	64	0,84	164	12	13
73270	PEAD	600	400	72	1,00	180	14	13
73271	PEAD	600	400	72	0,89	180	14	13
70520	PEAD	600	400	90	0,87	300	13	27
70521	PEAD	600	400	90	0,87	300	13	27
70522	PEAD	600	400	90	0,87	300	13	27

Referencia Reference	Material Material	Largo (mm) Length (mm)	Ancho (mm) Width (mm)	Alto (mm) Height (kg)	Peso (kg) Weight (kg)	Ud. por pallet Units	Capacidad l. Capacity l.	Página Page
70523	PEAD	600	400	90	0,87	300	13	27
70122	PEAD	600	400	100	1,31	148	19	13
71220	PEAD	600	400	118	1,08	105	22	15
71221	PP	600	400	118	1,08	105	22	15
71222	PEAD	600	400	118	1,15	105	22	15
71223	PEAD	600	400	118	1,22	105	22	15
71224	PP	600	400	118	1,22	105	22	15
70360	PEAD	600	400	120	1,43	85	23	9
73050	PEAD	600	400	120	1,26	100	26	14
85000	PP	600	400	120	1,39	240	21	19
70540	PEAD	600	400	125	1,42	200	18	27
70541	PEAD	600	400	125	1,42	200	18	27
70750	ABS	600	400	140	2,60	48		11
75150	PEAD	600	400	150	1,36	145	26	31
75151	PEAD	600	400	150	1,25	145	26	31
70370	PEAD	600	400	170	1,80	70	30	9
70371	PEAD	600	400	170	1,68	70	30	9
70751	PP	600	400	170	3,00	48		11
73060	PEAD	600	400	170	1,58	65	32	14
70710	PP	600	400	175	3,50	48		11
70720	PP	600	400	175	1,76	48		11
85100	PP	600	400	180	1,70	240	35	19
75462	PEAD	600	400	200	1,55	84	35	30
75461	PEAD	600	400	200	1,35	84	35	30
75160	PEAD	600	400	200	2,43	84	35	31
75161	PEAD	600	400	200	2,08	84	35	31
75200	PEAD	600	400	200	2,44	84	35	31
75201	PEAD	600	400	200	2,10	84	35	31
75351	PEAD	600	400	208	2,20	55	35	16
75352	PEAD	600	400	208	2,00	55	35	16
75353	PEAD	600	400	208	1,75	55	35	16
73020	PEAD	600	400	210	1,92	125	33	33
71401	PEAD	600	400	214	2,30	50	40	17
85200	PP	600	400	220	2,00	240	42	19
70380	PEAD	600	400	230	1,88	45	45	9
70381	PEAD	600	400	230	1,54	45	45	9
70382	PEAD	600	400	230	1,88	45	45	9
70383	PEAD	600	400	230	1,54	45	45	9
73160	PEAD	600	400	230	1,85	40	44	14
70800	PP	600	400	265	2,72	60	45	25
73100	PEAD	600	400	270	2,24	150	45	33
70660	PEAD	600	400	325	2,90	35	60	10
70661	PEAD	600	400	325	2,49	35	60	10
80000	PP	600	400	325	1,86	100		18
70920	PEAD	600	400	425	3,65	25	90	10
70921	PEAD	600	400	425	3,10	25	90	10
71110	PP	600	400		0,63	200		10
72662	PP	600	400		0,69	208		10
70170	PEAD	600	450	150	1,10	300	18	28
70171	PEAD	600	450	150	1,10	300	18	28
70172	PEAD	600	450	150	1,10	300	18	28
77530	PEAD	610	380	340	2,30	50	66	21
79360	PEAD	620	865	1114	14,14	10	360	42
79365	PEAD	620	865	1114	14,14	10	360	42

Referencia <i>Reference</i>	Material <i>Material</i>	Largo (mm) <i>Length (mm)</i>	Ancho (mm) <i>Width (mm)</i>	Alto (mm) <i>Height (kg)</i>	Peso (kg) <i>Weight (kg)</i>	Ud. por pallet <i>Units</i>	Capacidad l. <i>Capacity l.</i>	Página <i>Page</i>
70560	PP	625	425	123	1,99	72	28	12
70562	PP	625	425	145	2,15	72	28	12
70130	PP	646	445	81	1,31	160	18	13
73110	PEAD	650	460	130	1,65	160	19	28
73120	PEAD	650	460	130	1,65	160	19	28
70910	PEAD	661	454	410	3,87	30	90	20
71800	PEAD	690	590	565	5,06	16	180	21
75360	PEAD	700	380	185	1,44	100	36	31
73240	PEAD	740	640	120	2,22	50	41	32
70320	PEAD	770	490	120	2,20	60	30	21
74450	PP	800	600	120	4,40	34	45	17
70670	PEAD	800	600	171	2,47	60	62	32
74900	PP	800	600	220	5,75	20	90	17
74300	PP	800	600	325	7,05	14	130	17
74570	PP	800	600	425	8,20	14	175	17
72645	PP	800	600		1,00	100		17
70330	PEAD	805	450	155	2,46	105	30	29
75910	PEAD	920	550	510	6,75	20	200	33
79307	PEAD	1000	635	645	11,80	4	300	46
79743	PEAD	1012	654	75	3,80	40		47
72032	PEAD	1200	800	134	5,00	48		48
72033	PEAD	1200	800	134	6,00	48		48
72091	PEAD	1200	800	150	12,10	17		48
72092	PEAD	1200	800	150	14,00	17		48
72040	PEAD	1200	800	160	18,00	16		49
72042	PEAD	1200	800	160	18,00	16		49
79317	PEAD	1200	800	600	23,80	4	350	46
79617	PEAD	1200	800	800	29,46	3	525	46
79515	PEAD	1200	1000	580	31,37	4	450	46
79730	PEAD	1200	1000	760	31,21	4	610	47
79731		1120	920	600	30,56	4	610	47
72095	PEAD	1200	1000		17,50	17		49
72096	PEAD	1200	1000		18,50	17		49
79741	PEAD	1215	816	75	5,99	40		47
79740	PEAD	1225	1025	75	6,51	40		47
79751	PEAD	1360	778	1320	37,40	4	800	43
79130	PEAD	1370	1100	1330	50,92	3	1100	43
79131	PEAD	1370	1100	1330	50,92	3	1100	43
13030	PEAD	Ø290		262	0,48	360	10	38
13040	PEAD	Ø310		280	0,48	330	12	38
13140	PP	Ø335		160	0,33	432	10	39
13050	PEAD	Ø340		305	0,68	240	15	38
13060	PEAD	Ø360		335	0,83	180	20	38
23188	PEAD	Ø370		85	2,18	50		37
13150	PP	Ø380		180	0,53	288	15	39
13160	PP	Ø440		205	0,63	180	20	39
13255	PEAD	Ø455		505	2,07	100	50	37
23108	PEAD	Ø480		105	2,96	50		37
13170	PP	Ø490		230	0,89	144	30	39
13265	PEAD	Ø495		585	2,58	80	70	37
23180	PEAD	Ø495		730	3,61	60	95	37
23110	PEAD	Ø515		670	4,12	60	100	37
13180	PP	Ø535		250	1,09	90	35	39

ECONOMÍA CIRCULAR APLICADA EN ORIGEN

*CIRCULAR ECONOMY
APPLIED AT HOME*

**PROCESAMOS Y RECUPERAMOS LA MATERIA PRIMA EN
TU PLANTA GRACIAS A NUESTRO MOLINO MÓVIL**

*WE PROCESS AND RECOVER RAW MATERIALS AT
YOUR PLANT THANKS TO OUR MOBILE MILL*



Disponemos de un **molino móvil** que nos permite realizar la **recuperación del material directamente en tus instalaciones**, evitando el transporte de cajas voluminosas hacia nuestra planta.

Al moler el material en origen, el volumen se reduce de forma significativa, lo que nos permite transportar únicamente el material ya recuperado. Esto se traduce en:

- Menor coste logístico
- Menor espacio de almacenaje
- Menores emisiones de CO₂ por transporte
- Mayor eficiencia en la gestión de residuos y materia prima

Este proceso facilita la recuperación y reutilización del material dentro de un modelo real de **economía circular**, mejorando la sostenibilidad y el rendimiento global de la cadena productiva.

We operate a **mobile mill** that enables the **recovery of material directly at your facilities**, eliminating the need to transport bulky boxes to our plant.

By **milling the material on-site**, its volume is significantly reduced, allowing us to **transport only the recovered material**. This results in:

- Lower logistics and transportation costs
- Reduced storage requirements
- Lower CO₂ emissions due to reduced transportation
- Greater efficiency in material and waste management.

This process supports a **true circular economy model**, facilitating the reuse of recovered material while improving both sustainability and overall production efficiency.



**TRILLA ESTÁ REGISTRADO COMO
GESTOR DE RESIDUOS NO PELIGROSOS.**
*TRILLA IS REGISTERED AS MANAGER
OF NON-HAZARDOUS WASTE.*

DATOS GENERALES / GENERAL INFORMATION



TRANSPORTE / SHIPPING

MEDIDAS PALET PALLET DIMENSIONS	CAMIÓN TRUCK	CONTAINER 20' 20' CONTAINER	CONTAINER 40' 40' CONTAINER
1200 x 1000	26	11	22
1200 x 800	33	12	25



MATERIALES / MATERIALS

MATERIAL MATERIAL	TOLERANCIA TÉRMICA THERMAL TOLERANCE
PEAD	-40° C / +75° C
PP	-10° C / +115° C
PVC	-30° C / +80° C
ABS	-25° C / +90° C

Fabricados por inyección. / *Manufactured by injection.*

Colorante orgánico, libre de materiales pesados. / *Organic dye, free of heavy materials.*

Filtros UV. / *UV filters.*

Colores a determinar para cantidades superiores a 500 uds. / *Colours to be determined for quantities greater than 500 units.*



CERTIFICACIONES / CERTIFICATIONS

- REGISTRO SANITARIO NÚM. 39.00004064/M
HEALTH REGISTER NUM. 39.00004064/M



ISO 9001 : 2015 0.04.11111
ISO 14001 : 2015 3.00.20002



Calidad alimentaria. / *Food quality.*

Reciclables, cumplen la normativa de protección medioambiental. / *Recyclable, they comply with environmental protection legislation.*

Ensayos de migración de acuerdo a la directiva europea EU 10/2011. / *Migration tests according to European directive EU 10/2011.*

MANUTENCIÓN / SHIPPING



www.iptrilla.es

- INDUSTRIA / INDUSTRY •-----
- LABORATORIOS Y FARMACIA / LABORATORIES AND PHARMACY •-----
- PESCA Y CONSERVAS / FISHING AND CANNING •-----
- INDUSTRIA CÁRNICA / MEAT INDUSTRY •-----
- ALIMENTACIÓN / NUTRITION •-----
- LÁCTEAS / DAIRY •-----
- BODEGAS Y VENDIMIA / WINERIES AND HARVESTING •-----



**TRILLA ESTÁ REGISTRADO COMO
GESTOR DE RESIDUOS NO PELIGROSOS**
*TRILLA IS REGISTERED AS MANAGER OF
NON-HAZARDOUS WASTE*

TRILLA

TRILLA INDUPLAST IBÉRICA, S.L.U.

Avenida de Madrid, 86
28802, ALCALÁ DE HENARES (Madrid)

Tel. +34 91 889 07 00

+34 91 877 13 67

+34 91 880 78 61

comercial@iptrilla.es

www.iptrilla.es



**DEJANDO HUELLA
SIN DEJAR RASTRO**

Build to last, designed for the planet

www.iptrilla.es